



## Dixon Automatic Tool, Inc.

### SES Series - SEV, SMZ, SEM-V

High-Performance  
Automatic Screwdrivers and Nut  
Runners with Feeder

By: Stöger Automation

*Sales Representative in  
USA, Canada and Mexico  
For 24 years*

*Dixon Automatic Tool, Inc.  
Email: sales@dixonautomatic.com*



The high-performance SES/SEM Series Automatic Screwdrivers and Nut Runners enjoy intelligent functions that provide you with clear-cut benefits: the entire driving unit does not move due to the integrated stroke movements, just the screwdriver tool moves up and down. This preserves the drive and sensors.

The unit is designed for extremely high cycle times, since only small masses are moved. The screwdriver can be used for all driving positions and are therefore just as suited to stationary use as they are for operation on positioning systems and robots, in rotary table and transfer systems.

The system recognizes errors and issues via a NOK message. The connecting element is discharged at the same time so that the automatic driving process is not interrupted.

#### THE ADVANTAGES AT A GLANCE:

- ◆ *Slim design, also suitable for narrow screwdriver spacings.*
- ◆ *Drive-preserving functionality due to the integrated lifting movements for a long service life.*
- ◆ *Sensor system is not moved due to the integrated stroke movement and thereby preserved.*
- ◆ *Tool change in 10 seconds without the need for additional tools.*
- ◆ *Quality enhancement due to verifiability of the screw connection.*
- ◆ *Virtually maintenance free systems.*
- ◆ *Documentation of the tightening results.*
- ◆ *Bit stroke freely adjustable, nose piece is retained shortly before coming into contact with the component, thus avoiding damages to the component.*

# Automatic Screwdrivers for Screws



## Technical Data

	SES 1601	SES 2001	SES 2501	SES 3201	SEV 2001	SEV 2501	SEV 3201
Screw head $\varnothing$ max	7*	11*	15*	24*	10*	14*	23*
Screw size	M2 – M4*	M2 – M5*	M4 – M6*	M5 – M10*	M2 – M5*	M4 – M6*	M5 – M10*
Torque (Nm)	0.03 – 1.6	0.2 – 4.5	0.5 – 12	1.0 – 45	0.2 – 4.5	0.5 – 12	1.0 – 45
Feed stroke (mm); depending on model	15 or 30	25 or 30	35 or 70	50 or 100	approx. 80	approx. 80	approx. 80
Vacuum version	no	no	no	no	yes	yes	yes
A (mm)	25	30	38	50	56	62	72
B (mm)	42	58	68	86	80	95	110
C (mm)	55	73	87	111	97	114	135

\* Standard, other sizes possible.

### SES

### SEV (Vacuum Version)

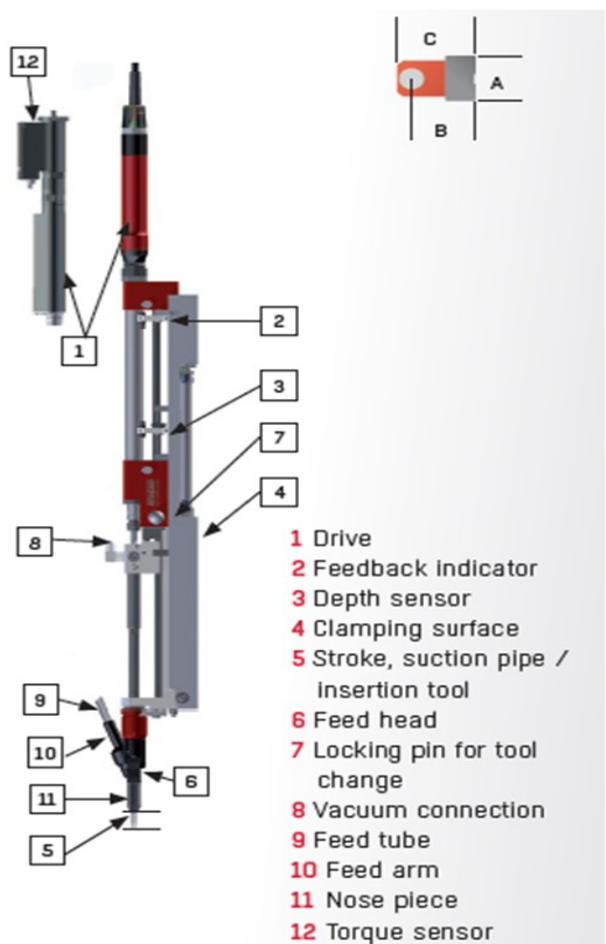
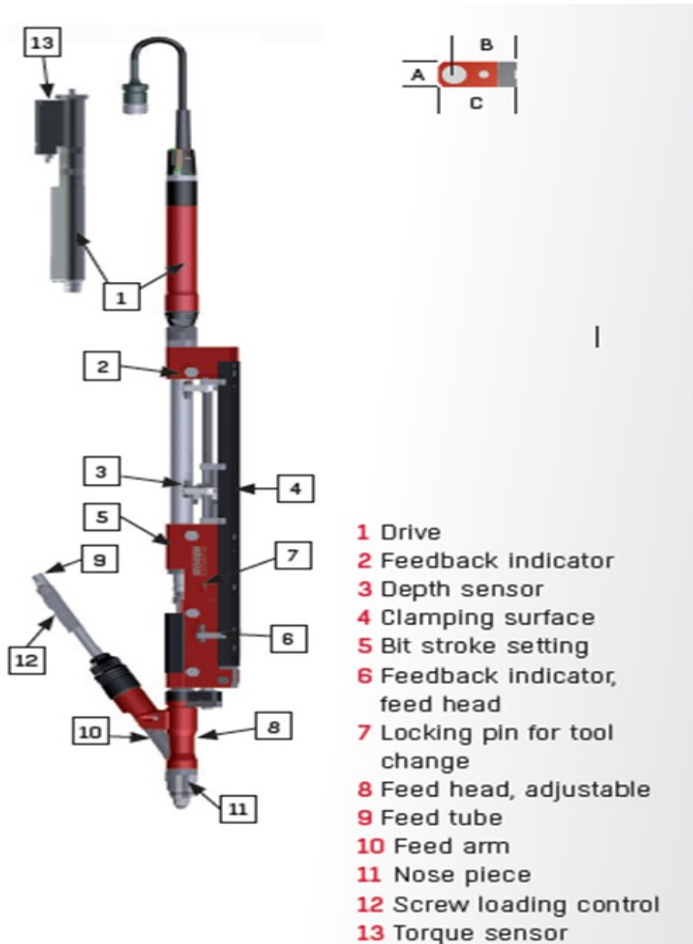

# Automatic Nut Runners



Typical Nuts

## Technical Data

	SMZ 32	SEM-V 1601	SEM-V 2001	SEM-V 2501	SEM-V 3201
Nut size (max.)	M8*	M4	M6	M8	M12
Torque (Nm)	1.0 – 4.5	0.03 – 1.6	0.2 – 4.5	0.5 – 12	1.0 – 45
Vacuum version	no	yes	yes	yes	yes
Controlled centering needle	yes	no	no	no	no
Overstroke (mm)	50	approx. 40-60	approx. 60	approx. 80	approx. 100
A (mm)	50	25	30	38	50
B (mm)	82	42	58	68	86
C (mm)	189	55	73	87	111

\* Standard, other sizes possible.

## Modules

### SMZ 32 (with Controlled Centering Needle)

### SEM-V (Vacuum Version)

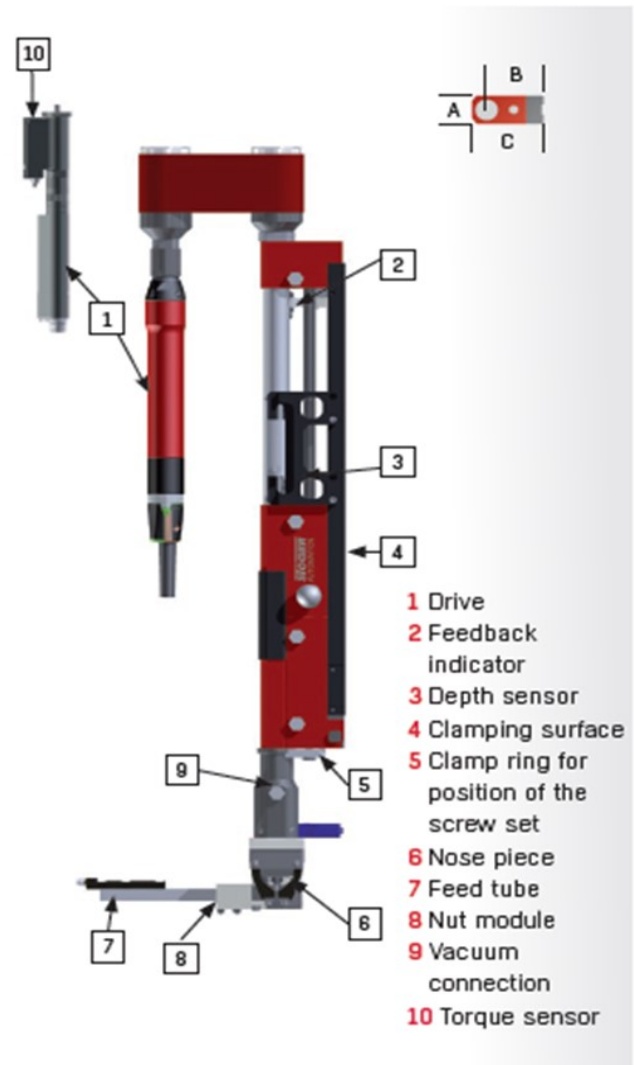
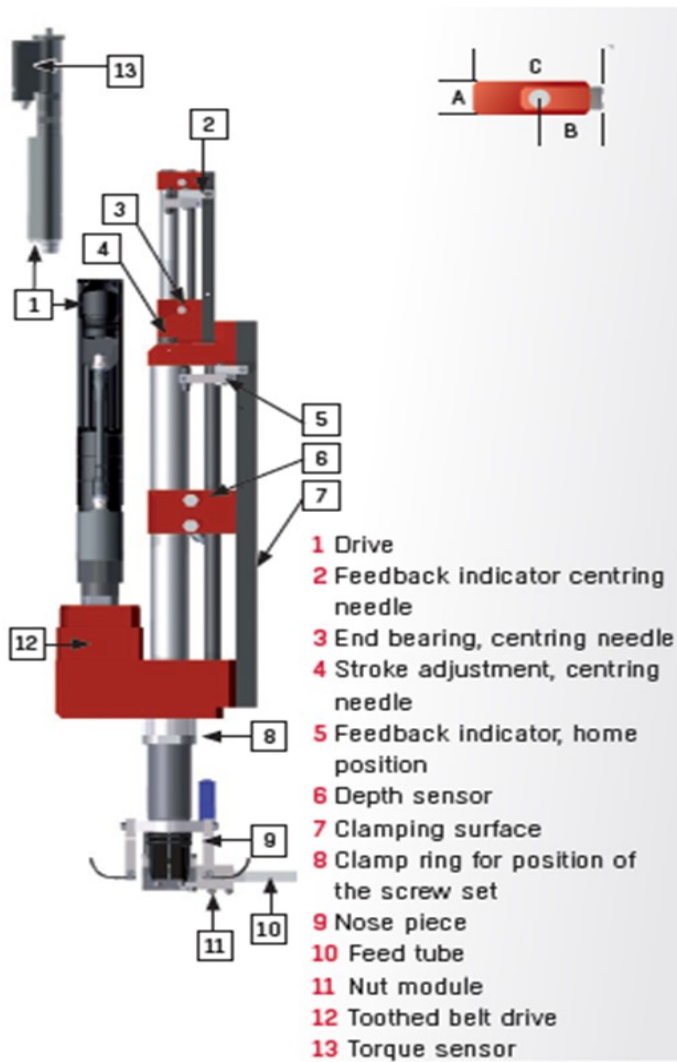

## Vacuum Module Function

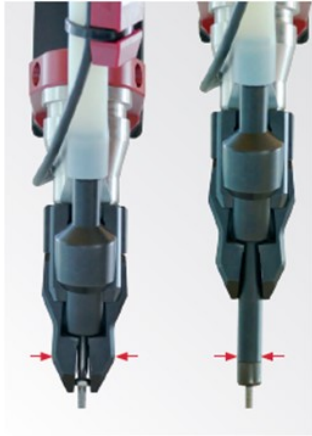

The screwdriver tool is enclosed by a tube in which a vacuum is generated. It retains the screw and facilitates depositing at the screw location.

The screwdriver tool extends and drives in the screw.

The space requirement around the screw location is reduced significantly since the diameter of the tube is only approx. 1-2mm larger

### **Interfering Edges**

*Interfering edges are single or multi-sided contours or super structures, which are found at the screw location or in close proximity (20mm diameter and up to 1,000mm in height). If you are not sure as to whether your component is designed for automated handling, we will be happy to help you in customizing the screw location.*

## User-Friendly Maintenance

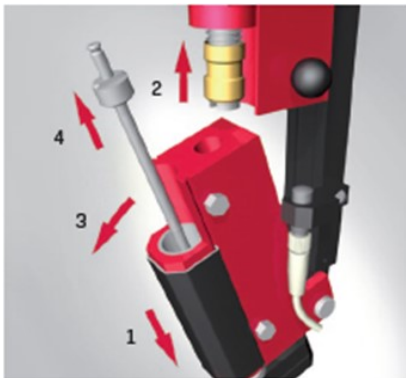

- + Feed arm detachable without tools, important to eliminate interference with deformed screws.
- + Simple adjustment of the depth sensor with adjusting wheel.

### **Tool Change in Under 10 Seconds**

1. Push the protection cap downwards
2. Release quick fasteners
3. Swivel out feed stroke

### **Drive**

- + Open drive concept
- + All brands possible
- + Optionally with angle drive for reducing the space requirement
- + With or without torque transducer and rotational angle measurement



*Sales Representative in USA, Canada and Mexico*

**DIXON AUTOMATIC TOOL, INC.**

**2300 – 23<sup>RD</sup> AVENUE**

**ROCKFORD, IL 61104**

**PHONE: 815-226-3000**

**EMAIL: [sales@dixonautomatic.com](mailto:sales@dixonautomatic.com)**

**[www.dixonautomatic.com](http://www.dixonautomatic.com)**